

Aslo

INSTRUÇÕES
INSTRUCCIONES
INSTRUCTIONS

MODE D'EMPLOI
ANLEITUNG

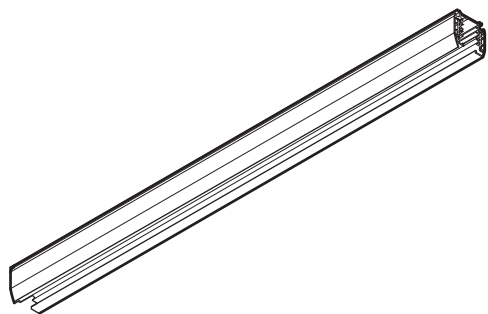

REF:
ASCS3C2BR ASCS3C2PR
ASCS3C3BR ASCS3C3PR

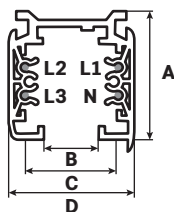

REF.	DIM.	A	B	C	D
ASCS3C2BR	2 m	33 mm	15 mm	22 mm	32 mm
ASCS3C2PR					
ASCS3C3BR	3 m	33 mm	15 mm	22 mm	32 mm
ASCS3C3PR					

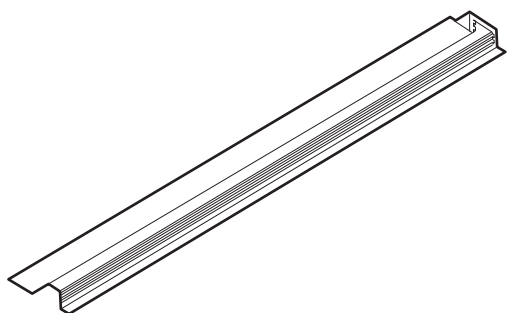

REF:
ASCE3C2BR ASCE3C2PR
ASCE3C3BR ASCE3C3PR

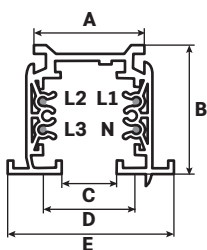

REF.	DIM.	A	B	C	D	E
ASCE3C2BR	2 m	33 mm	15 mm	22 mm	32 mm	56 mm
ASCE3C2PR						
ASCE3C3BR	3 m	33 mm	15 mm	22 mm	32 mm	56 mm
ASCE3C3PR						

ACESSÓRIOS - NÃO INCLUÍDOS

ACCESORIOS - NO INCLUIDOS
ACCESSORIES - NOT INCLUDED
ACCESSOIRES - NON INCLUS
ZUBEHÖR - NICHT IM LIEFERUMFANG ENTHALTEN

ACESSÓRIOS CALHA SALIENTE ACCESORIOS PARA CARRIL DE SUPERFICIE

ACCESSORIES FOR SURFACE MOUNTED TRACK ACCESSOIRES POUR RAIL EN SAILLIE

ZUBEHÖR FÜR MONTAGESCHIENEN

ASUCS3CBR
ASUCS3CPR

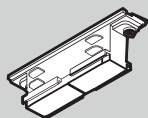

ASUACS3CBR
ASUACS3CPR

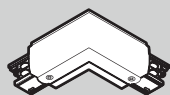

ASACS3CBR
ASACS3CPR

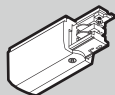

ASTFCS3CBR
ASTFCS3CPR

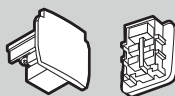

ASBCS3CBR
ASBCS3CPR



ASCSCSBR
ASCSCSPR



ACESSÓRIOS CALHA EMBUTIR ACCESORIOS PARA CARRIL EMPORTABLE

ACCESSORIES FOR RECESSED TRACK ACCESSOIRES POUR RAIL ENCASTRABLE

ZUBEHÖR FÜR EINBAUSCHIENEN

ASUCE3CBR
ASUCE3CPR

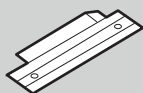

ASUACE3CBR
ASUACE3CPR

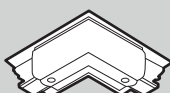

ASACE3CBR
ASACE3CPR

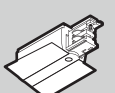

ASTFCE3CBR
ASTFCE3CPR

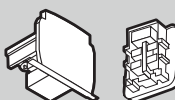

MONTAGEM / INSTALAÇÃO
MONTAJE / INSTALACIÓN

ASSEMBLY / INSTALLATION
MONTAGE / INSTALLATION

AUFBAU / INSTALLATION

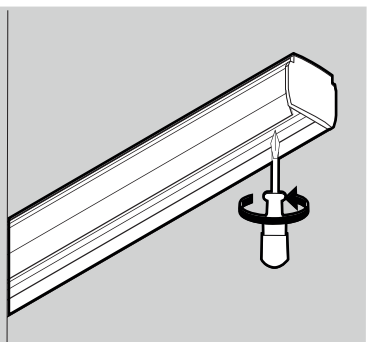
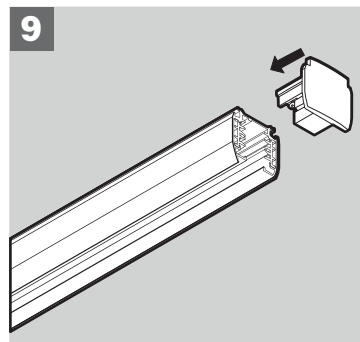
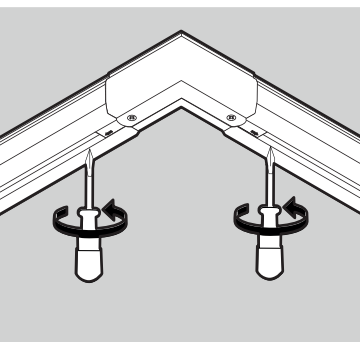
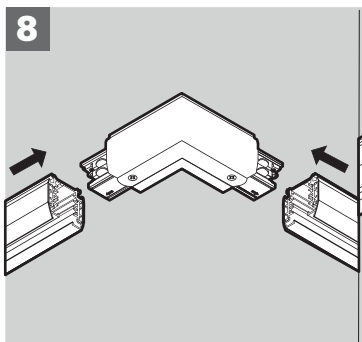
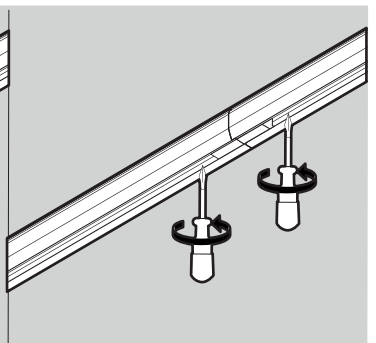
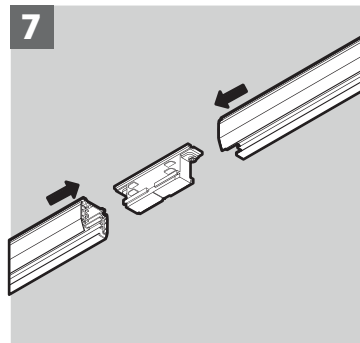
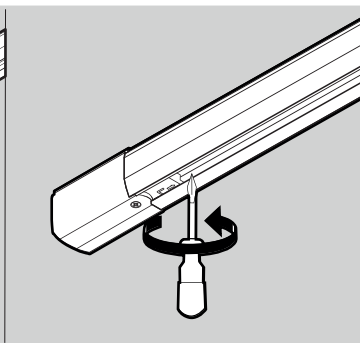
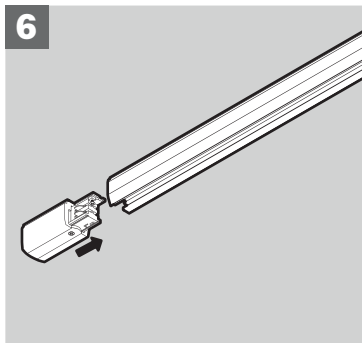
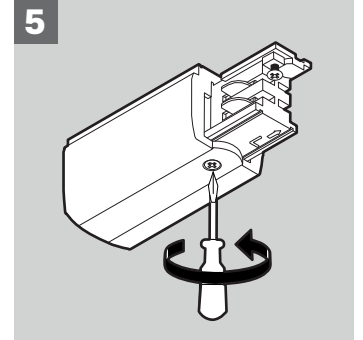
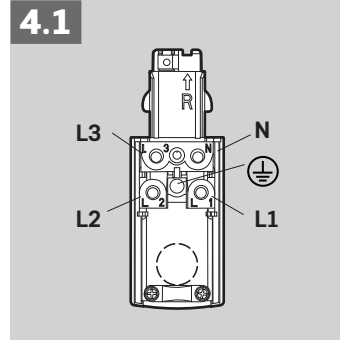
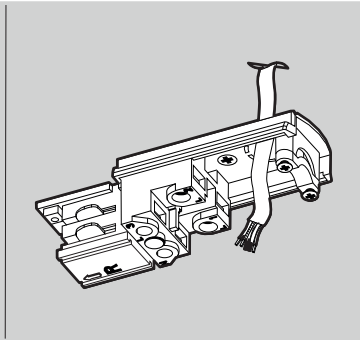
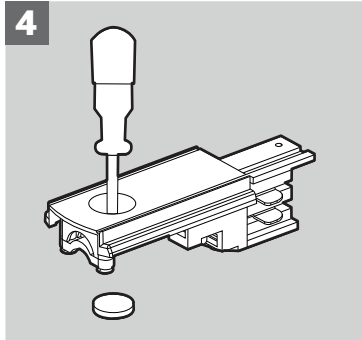
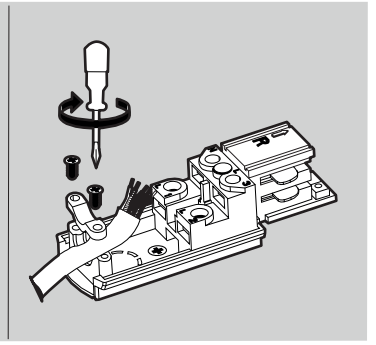
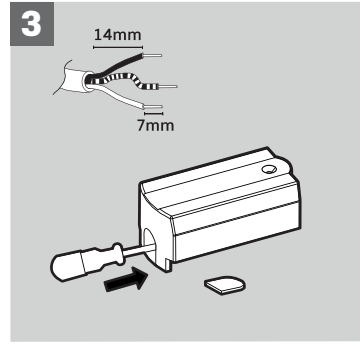
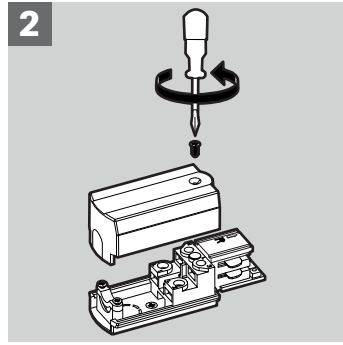
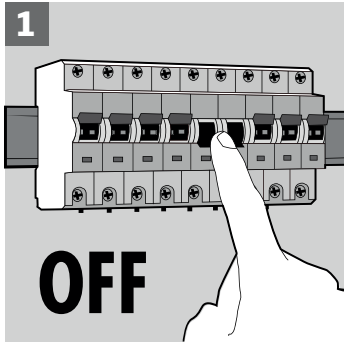

TIPO DE INSTALAÇÃO - CALHA SALIENTE
TIPO DE INSTALACIÓN - CARRIL DE SUPERFICIE
MOUNTING TYPE - SURFACE - MOUNTED TRACK

TYPE D'INSTALLATION - RAIL EN SAILLIE
EINBAUART - MONTAGESCHIENE

10

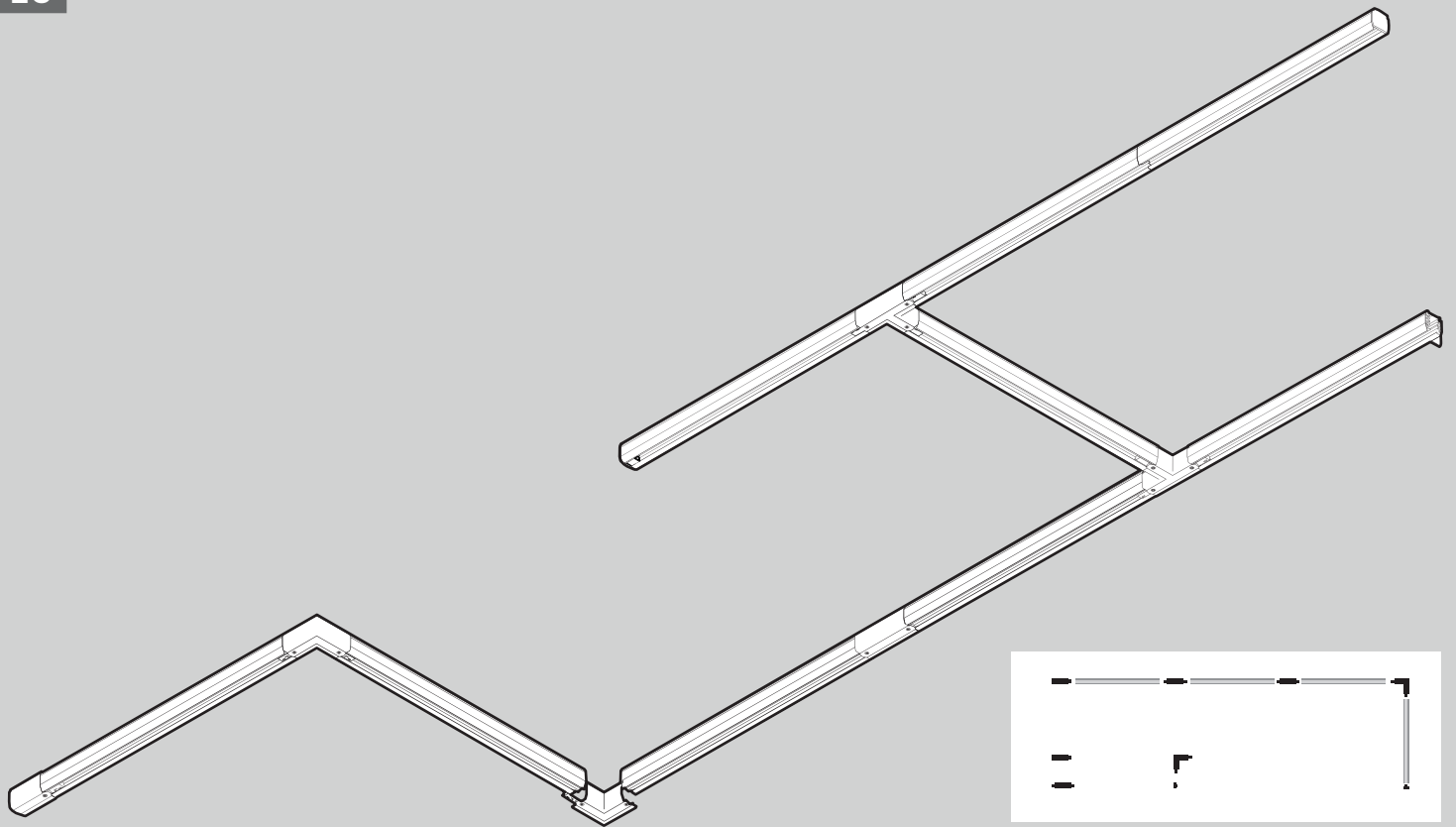

TIPO DE INSTALAÇÃO - CALHA EMBUTIR
TIPO DE INSTALACIÓN - CARRIL DE EMPOTRABLE
MOUNTING TYPE - RECESSED TRACK

TYPE D'INSTALLATION - RAIL ENCASTRABLE
EINBAUART - EINBAUSCHIENE

11

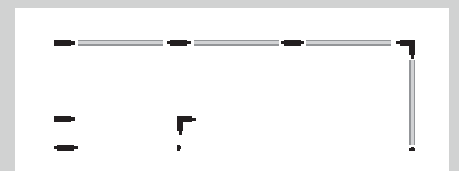
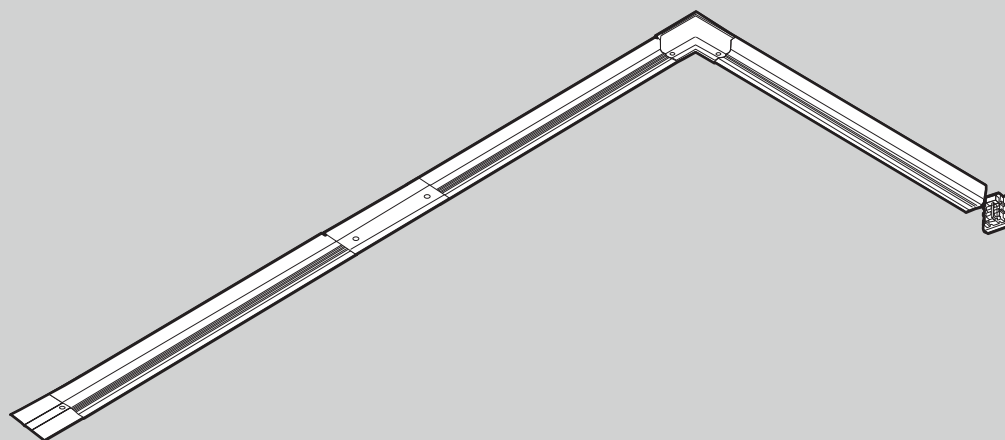

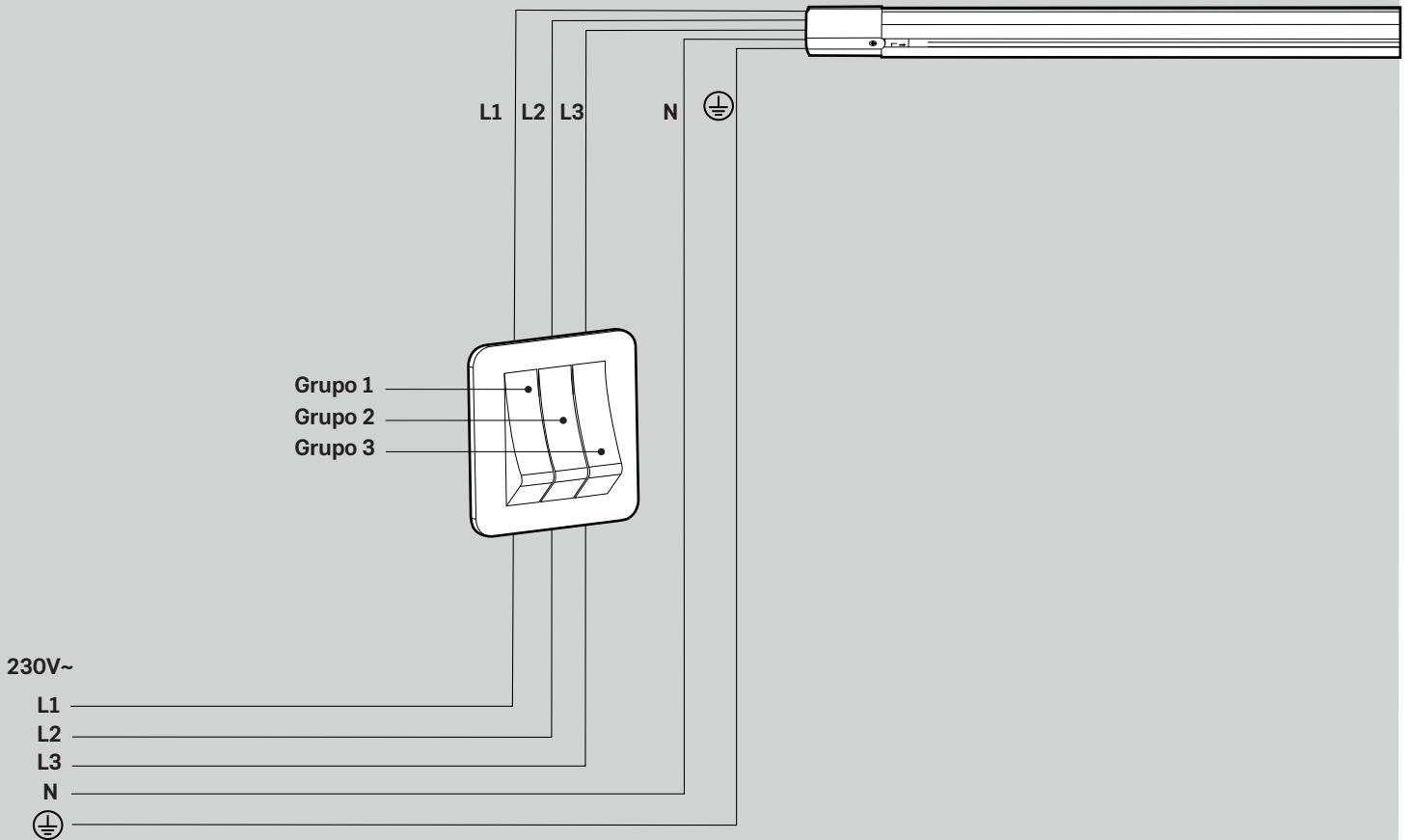

**NUNCA COLOQUE EQUIPAMENTOS ELÉTRICOS
E/OU ELETRÓNICOS NO LIXO DOMÉSTICO!**

Segundo a diretiva europeia 2012/19/CE relativa aos resíduos de equipamentos elétricos e/ou eletrónicos e a respetiva transposição para o direito interno, os equipamentos usados têm de ser recolhidos separadamente e entregues nos locais de recolha previstos para o efeito. Pode obter informações relativas à eliminação dos equipamentos usados através dos responsáveis legais pela reciclagem no seu município.



**NO DESECHE NUNCA LOS APARATOS ELÉCTRICOS Y/O ELECTRÓNICOS
EN LA BASURA DOMÉSTICA.**

Según la norma europea 2012/19/CE al respecto de los residuos de herramientas eléctricas y electrónicas y su transposición para el derecho interno, estas herramientas tienen de ser recogidas separadamente y entregadas en los locales de recogida previsto al efecto. Puede obtener información acerca de la eliminación de la máquina utilizada a través de los responsables legales del reciclaje en su municipio.



**NEVER DISPOSE OF ELECTRICAL AND/OR ELECTRONIC
EQUIPMENT IN THE HOUSEHOLD WASTE!**

According to the European Directive 2012/19 /EC on electrical and electronic equipment waste and its transposition into national law, power tools must be collected separately and delivered to the collection sites intended for this purpose. You can get information regarding the disposal of the power tool through the person in charge of recycling in your city.



**NE JETEZ JAMAIS LES ÉQUIPEMENTS ÉLECTRIQUES ET/OU ÉLECTRONIQUES
AVEC LES ORDURES MÉNAGÈRES!**

D'après la directive européenne 2012/19/CE concernant les déchets d'équipements électriques et électroniques et à sa transposition en droit national, les outils électriques usagés doivent être collectés séparément et remis aux points de collecte prévus à cet effet. Vous pouvez obtenir des informations sur l'élimination de la visseuse à choc sans fil utilisé auprès des responsables du service environnement de votre commune.



**WERFEN SIE ELEKTRO- UND/ODER ELEKTRONIKGERÄTE
NIEMALS IM HAUSMÜLL WEG!**

Gemäß der europäischen Richtlinie 2012/19/EG über Abfälle von Elektro- und Elektronikgeräten und deren Umsetzung in nationales Recht müssen gebrauchte Geräte separat gesammelt und an den dafür vorgesehenen Sammelstellen abgegeben werden. Weitere Informationen zur Entsorgung von Altgeräten erhalten Sie bei den zuständigen Stellen für Recycling in Ihrer Gemeinde.



CERTIFICADO DE GARANTIA

A garantia deste produto está de acordo com a lei em vigor a partir da data de compra. Deverá, pois, guardar a prova de compra durante esse período de tempo. A garantia engloba qualquer defeito de fabrico, de material ou de funcionamento, assim como os sobressalentes e trabalhos necessários para a sua recuperação.

Excluem-se da garantia a má utilização do produto, eventuais reparações efetuadas por pessoas não autorizadas (fora da assistência da marca ASLO), assim como qualquer estrago causado pela utilização da mesma.

CERTIFICADO DE GARANTIA

La garantía de este producto está en conformidad con la ley vigente a partir de la fecha de compra. Por lo tanto, debe guardar el comprobante de compra durante ese período de tiempo. La garantía cubre cualquier defecto de fabricación, material o funcionamiento, así como los repuestos y el trabajo necesario para su reparación.

Si excluyen de la garantía el malo uso del producto, eventual reparaciones efectuadas por personas no autorizadas (fuera de la asistencia de la marca ASLO), así como cualquier daño causado por el uso.

WARRANTY TERMS

The warranty for this product is in accordance with the law in force from the date of purchase. You should, therefore, keep your proof of purchase during this period. The warranty covers any manufacturing defect in material or operation, as well as parts and work needed for their repairing.

Excluded from the warranty are the misuse of the product, any repairs carried out by unauthorized individuals (outside the service center of the brand ASLO) as well as any damage caused by its use.

CERTIFICAT DE GARANTIE

La garantie de ce produit est conforme à la loi en vigueur à partir de la date d'achat. Vous devrez, pourtant, garder la preuve d'achat pendant cette période. La garantie englobe n'importe quel défaut de fabrication, du matériel ou de fonctionnement, ainsi que les pièces de rechange et les travaux nécessaires à sa récupération.

Sont exclues de la garantie la mauvaise utilisation du produit, les éventuelles réparations réalisées par des personnes non autorisées (en dehors de l'assistance de la marque ASLO), ainsi que n'importe quel dommage causé par l'utilisation de l'appareil.

GARANTIEZERTIFIKAT

Die Garantie für dieses Produkt richtet sich nach den geltenden gesetzlichen Bestimmungen ab dem Kaufdatum. Bewahren Sie daher unbedingt den Kaufbeleg für die Dauer des Garantiezeitraums auf.

Die Garantie umfasst alle Herstellungsfehler, Materialmängel sowie Funktionsstörungen, einschließlich der notwendigen Ersatzteile und Reparaturen zur Behebung der Mängel.

Von der Garantie ausgenommen sind Schäden, die durch unsachgemäße Nutzung des Produkts, Reparaturen durch nicht autorisierte Personen (außerhalb des ASLO-Service) oder durch unsachgemäße Handhabung entstehen.

DECLARAÇÃO UE DE CONFORMIDADE

CENTRAL LOBÃO S.A.
RUA DA GÂNDARA, 664
4520-606 S. JOÃO DE VER VFR

Declara para os devidos efeitos que os artigos a seguir descritos:

DESCRIÇÃO	CÓDIGO
CALHA SALIENTE COM 3 CIRCUITOS 2M BRANCO ASLO	ASCS3C2BR
CALHA SALIENTE COM 3 CIRCUITOS 3M BRANCO ASLO	ASCS3C3BR
CALHA SALIENTE COM 3 CIRCUITOS 2M PRETO ASLO	ASCS3C2PR
CALHA SALIENTE COM 3 CIRCUITOS 3M PRETO ASLO	ASCS3C3PR
CALHA ENCASTRAR COM 3 CIRCUITOS 2M BRANCO ASLO	ASCE3C2BR
CALHA ENCASTRAR COM 3 CIRCUITOS 3M BRANCO ASLO	ASCE3C3BR
CALHA ENCASTRAR COM 3 CIRCUITOS 2M PRETO ASLO	ASCE3C2PR
CALHA ENCASTRAR COM 3 CIRCUITOS 3M PRETO ASLO	ASCE3C3PR

Estão de acordo com as disposições da **Diretiva 2014/35/EU**, relativa à harmonização das legislações dos Estados-Membros respeitantes aos equipamentos elétricos projetados para uso dentro de certos limites de tensão, cumprindo as seguintes normas:

EN 60950-1:2006+A11:2009+A1:2010+A12:2011+A2:2013

Os produtos acima mencionados estão em conformidade com a **Diretiva RoHS 2011/65/EU** e respetiva emenda **Diretiva 2015/863/EU**

IEC 62321-3-1:2013, IEC 62321-5:2013, IEC 62321-6:2015, IEC 62321-7-1:2015, IEC 62321-4:2013+AMD1:2017, IEC 62321:2008

S. João de Ver, 16 de dezembro de 2024

Central Lobão S.A.



O Técnico Responsável
(Hugo Santos)

Processo técnico compilado por: Hugo Santos

MADE IN P.R.C.

Aslo

BRIGHTER LIFE

aslo.pt

**CENTRAL LOBÃO SA.
RUA DA GÂNDARA, 664
4520-606 S. JOÃO DE VER
STA. MARIA DA FEIRA PORTUGAL**

