

Aslo

INSTRUÇÕES

INSTRUCCIONES

INSTRUCTIONS

MODE D'EMPLOI

ANLEITUNG

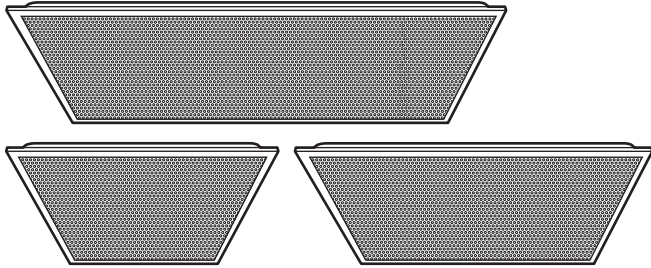

REF:
ASIGLA306024C3
ASIGLA606040C3
ASIGLA3012040C3

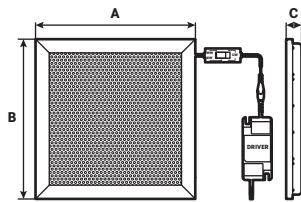

01.09.2021

ENERGY
 2019/2015

E

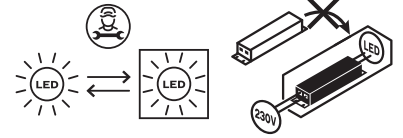

REF.	W	LUMENS	A	B	C
ASIGLA306024C3	24 W	3120 LM	595 mm	295 mm	32 mm
ASIGLA606040C3	40 W	5200 LM	595 mm	595 mm	32 mm
ASIGLA3012040C3	40 W	5200 LM	1195 mm	295 mm	32 mm

ACESSÓRIOS NECESSÁRIOS - NÃO INCLUÍDOS

ACCESORIOS REQUERIDOS - NO INCLUIDOS
 REQUIRED ACCESSORIES - NOT INCLUDED
 ACCESSOIRES REQUIS - NON INCLUS
 ERFORDERLICHES ZUBEHÖR - NICHT IM LIEFERUMFANG ENTHALTEN

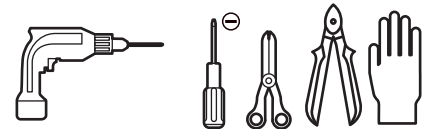

MONTAGEM / INSTALAÇÃO - A

ASSEMBLY / INSTALLATION - A

AUFBAU / INSTALLATION - A



EMBUTIDA
 EMPOTRADA ENCASTRÉE
 RECESSED EINBAUEN

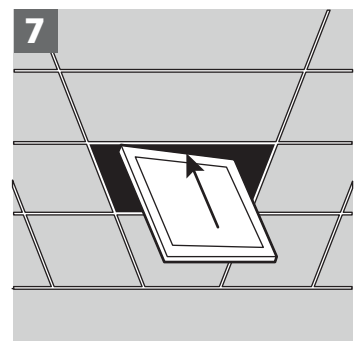
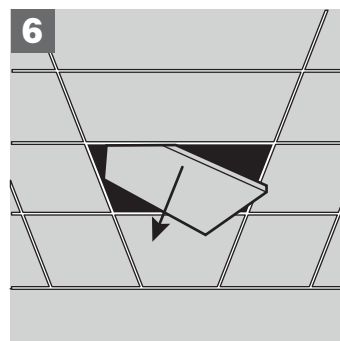
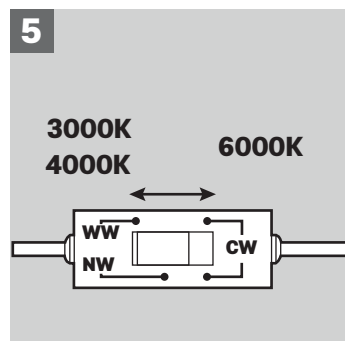
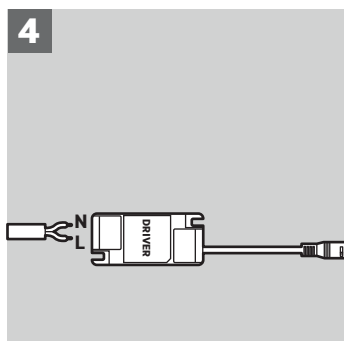
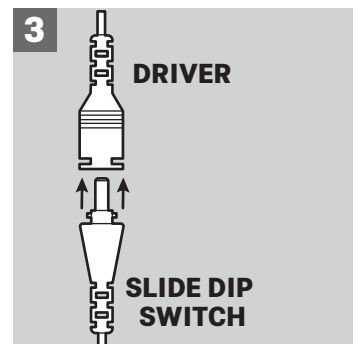
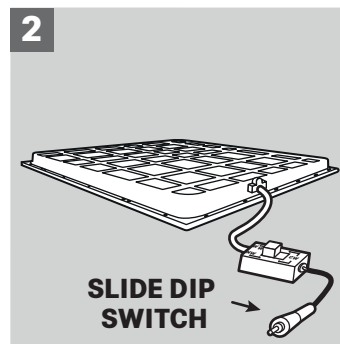
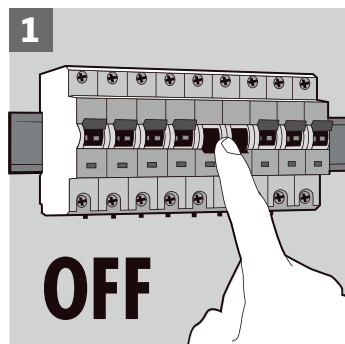
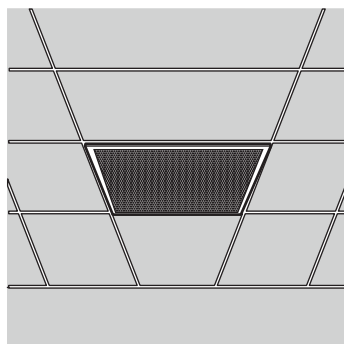

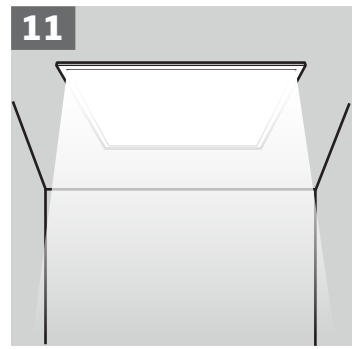
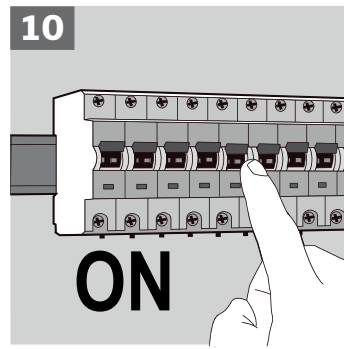
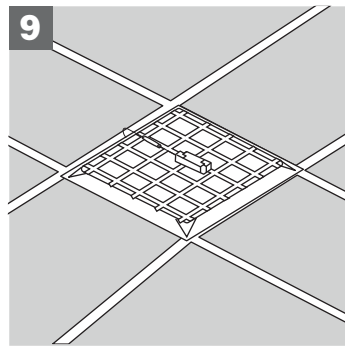
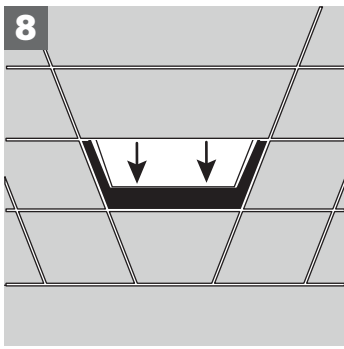

MONTAGEM / INSTALAÇÃO - B
MONTAJE / INSTALACIÓN - B

ASSEMBLY / INSTALLATION - B
MONTAGE / INSTALLATION - B

AUFBAU / INSTALLATION - B

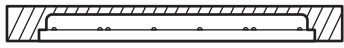

EMBUTIDA COM MOLDURA DE ENCASTRAR
EMPOTRADA CON MARCO DE EMPOTRAR
RECESSED INSTALLATION WITH FRAME

MONTAGE ENCASTRÉE AVEC CABLE ENCASTRÉ
UNTERPUTZMONTAGE MIT EINBAURAHMEN MÖGLICH

ACESSÓRIOS DISPONÍVEIS - NÃO INCLUÍDOS - ASMEDAY6060 / ASMEDAY3060 / ASMEDAY30120
ACCESORIOS DISPONIBLES - NO INCLUIDOS - ASMEDAY6060 / ASMEDAY3060 / ASMEDAY30120
ACCESSORIES AVAILABLE - NOT INCLUDED - ASMEDAY6060 / ASMEDAY3060 / ASMEDAY30120
ACCESSOIRES DISPONIBLES - ACCESSOIRES NON INCLUS - ASMEDAY6060/ ASMEDAY3060 / ASMEDAY30120
ZUBEHÖR ERHÄLTICH - ZUBEHÖR NICHT ENTHALTEN - ASMEDAY6060/ ASMEDAY3060 / ASMEDAY30120

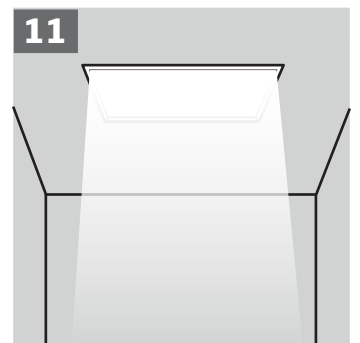
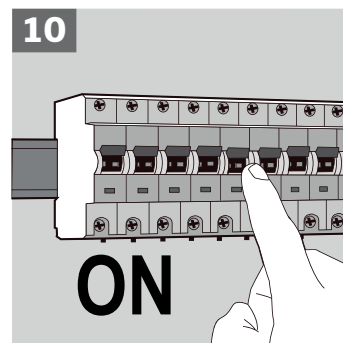
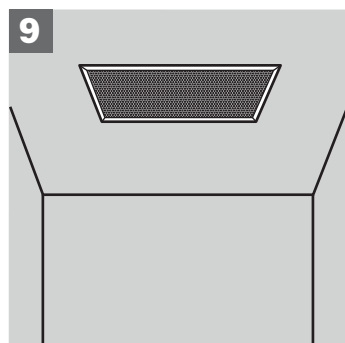
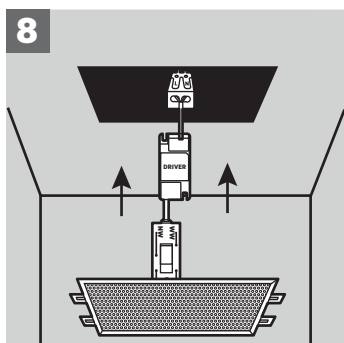
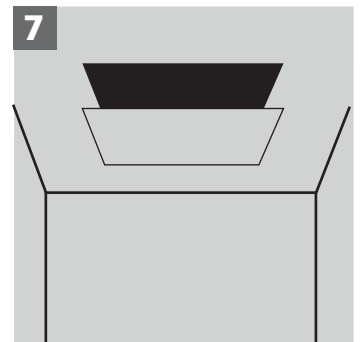
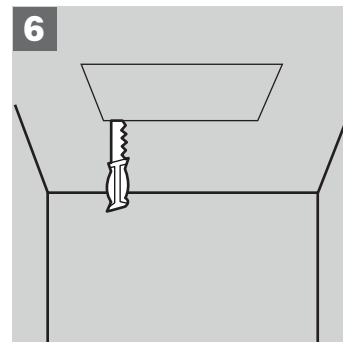
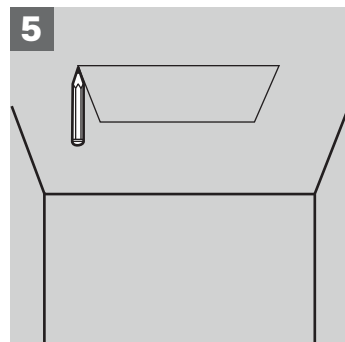
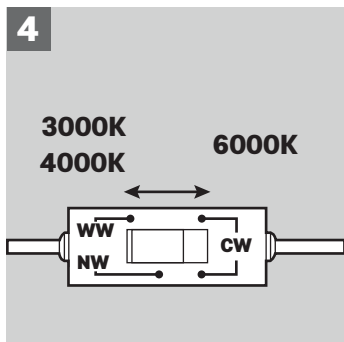
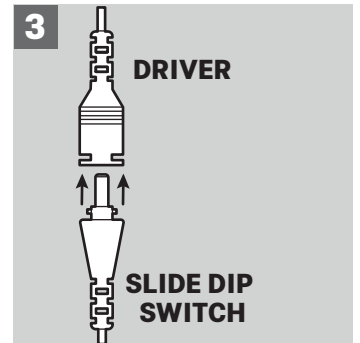
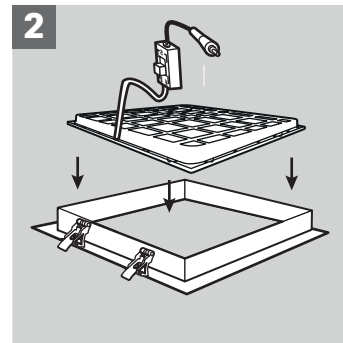
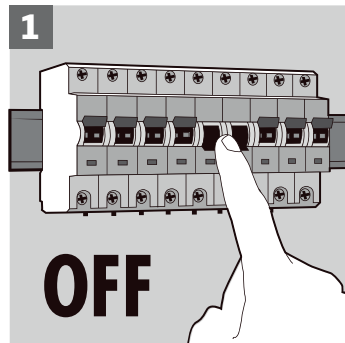
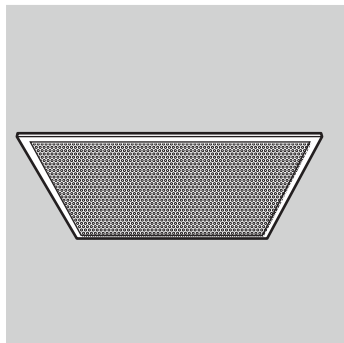
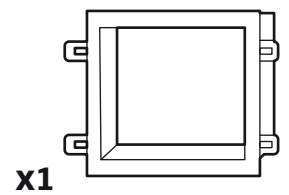

MONTAGEM / INSTALAÇÃO - C
MONTAJE / INSTALACIÓN - C

ASSEMBLY / INSTALLATION - C
MONTAGE / INSTALLATION - C

AUFBAU / INSTALLATION - C

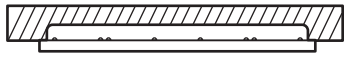

MOLAS DE FIXAÇÃO
GRAPAS DE FIJACIÓN
SPRING INSTALLATION

CLIPS DE FIXATION
BEFESTIGUNGSKLEMMEN

ACESSÓRIOS DISPONÍVEIS - NÃO INCLUÍDOS - ASCMFDAY
ACCESORIOS DISPONIBLES - NO INCLUIDOS - ASCMFDAY
ACCESSORIES AVAILABLE - NOT INCLUDED - ASCMFDAY
ACCESSOIRES DISPONIBLES - ACCESSOIRES NON INCLUS - ASCMFDAY
ZUBEHÖR ERHÄLTICH - ZUBEHÖR NICHT ENTHALTEN - ASCMFDAY

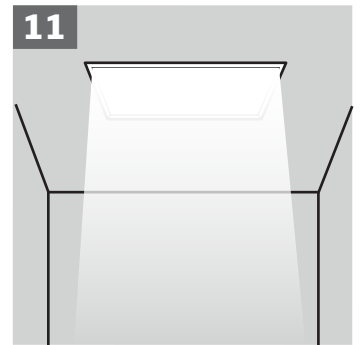
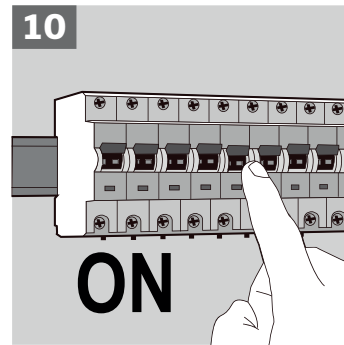
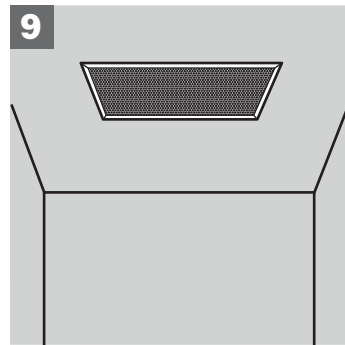
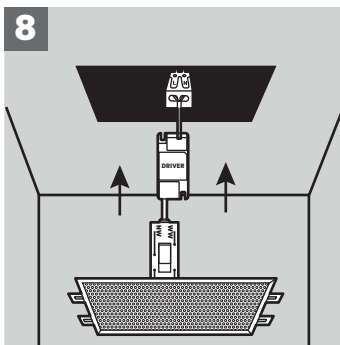
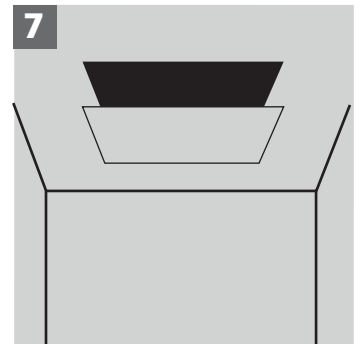
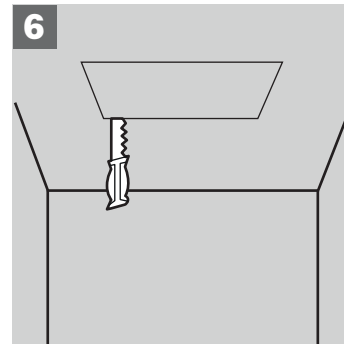
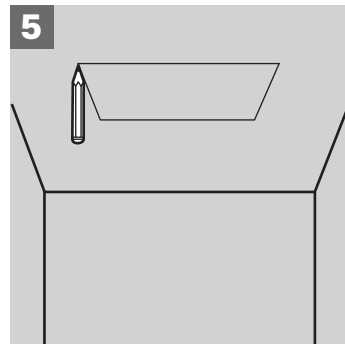
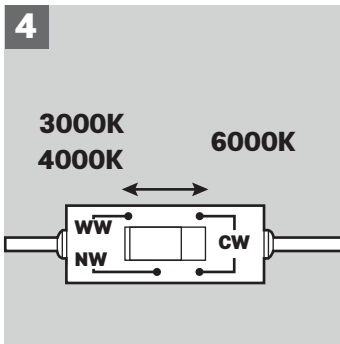
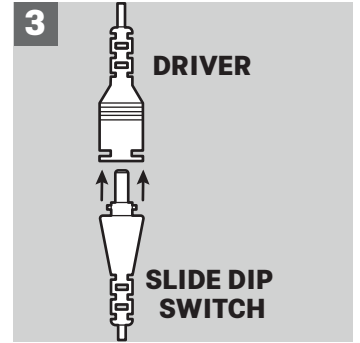
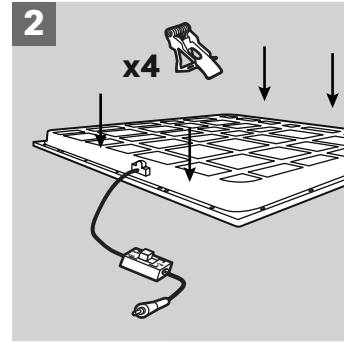
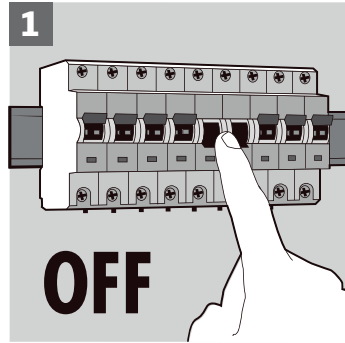
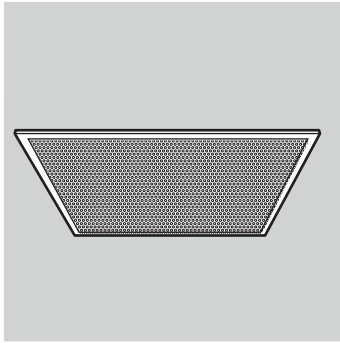
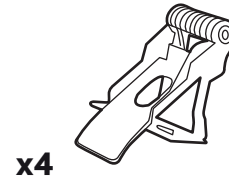

MONTAGEM / INSTALAÇÃO - D
MONTAJE / INSTALACIÓN - D

ASSEMBLY / INSTALLATION - D
MONTAGE / INSTALLATION - D

AUFBAU / INSTALLATION - D

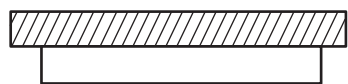

SALIENTE COM MOLDURA DE MONTAGEM DE SUPERFÍCIE
 EN UN MARCO EN SUPERFICIE
 SURFACE MOUNTED

DU CADRE DE MONTAGE EN SAILLIE
 AUFPUTZMONTAGE MIT
 ENTSPRECHENDEM RAHMEN MÖGLICH

ACESSÓRIOS DISPONÍVEIS - NÃO INCLUÍDOS - ASMSDAY6060 / ASMSDAY3060 / ASMSDAY30120
 ACCESORIOS DISPONIBLES - NO INCLUIDOS - ASMSDAY6060 / ASMSDAY3060 / ASMSDAY30120
 ACCESSORIES AVAILABLE - NOT INCLUDED - ASMSDAY6060 / ASMSDAY3060 / ASMSDAY30120
 ACCESSOIRES DISPONIBLES - ACCESSOIRES NON INCLUS - ASMSDAY6060 / ASMSDAY3060 / ASMSDAY30120
 ZUBEHÖR ERHÄLTlich - ZUBEHÖR NICHT ENTHALTEN - ASMSDAY6060 / ASMSDAY3060 / ASMSDAY30120

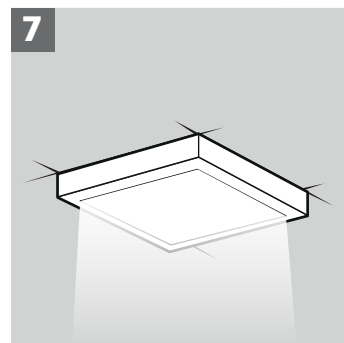
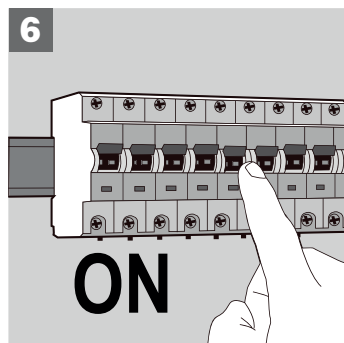
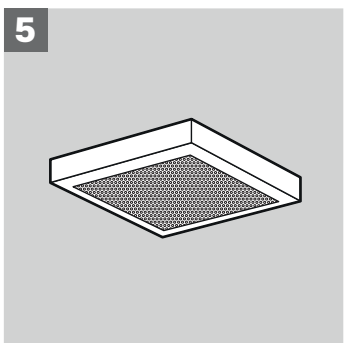
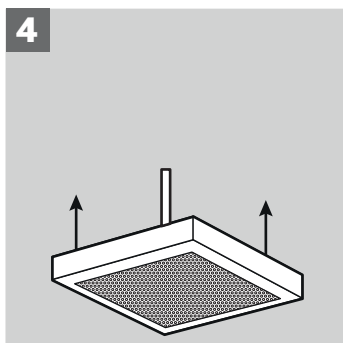
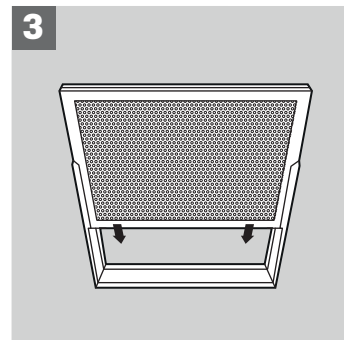
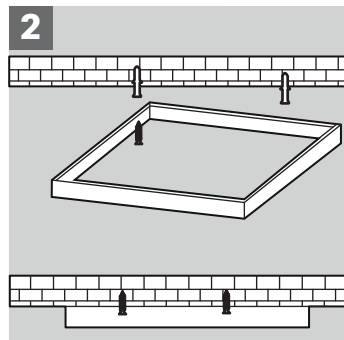
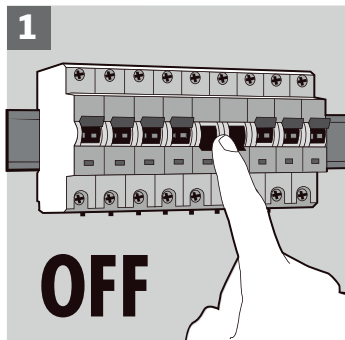
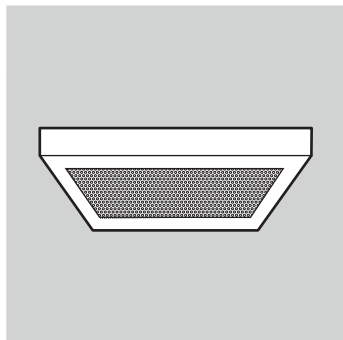
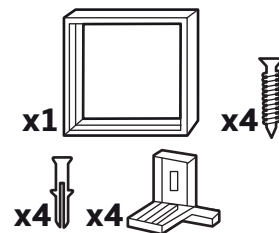

MONTAGEM / INSTALAÇÃO - E
MONTAJE / INSTALACIÓN - E

ASSEMBLY / INSTALLATION - E
MONTAGE / INSTALLATION - E

AUFBAU / INSTALLATION - E



SUSPensa
 SUSPENDIDA
 SUSPENDED
 SUSPENDUE
 AUFHÄNGUNG MÖGLICH

ACESSÓRIOS DISPONÍVEIS - NÃO INCLUÍDOS - ASCSDAY
 ACCESORIOS DISPONIBLES - NO INCLUIDOS - ASCSDAY
 ACCESSORIES AVAILABLE - NOT INCLUDED - ASCSDAY
 ACCESSOIRES DISPONIBLES - ACCESSOIRES NON INCLUS - ASCSDAY
 ZUBEHÖR ERHÄLTlich - ZUBEHÖR NICHT ENTHALTEN - ASCSDAY

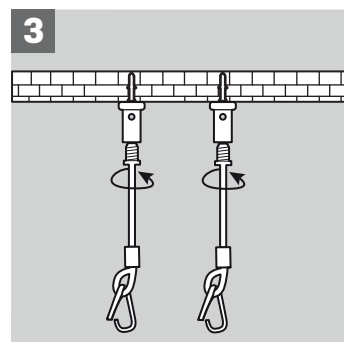
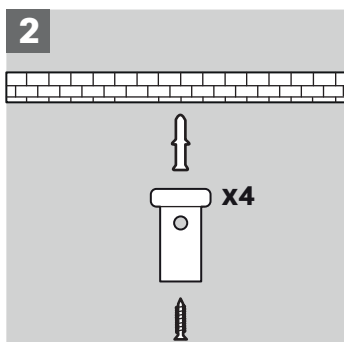
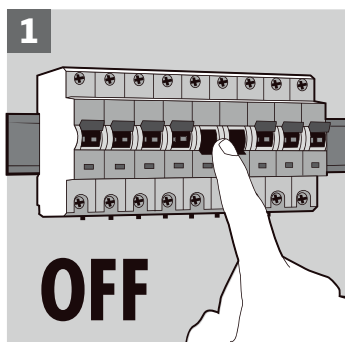
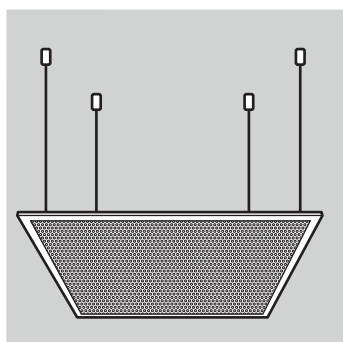
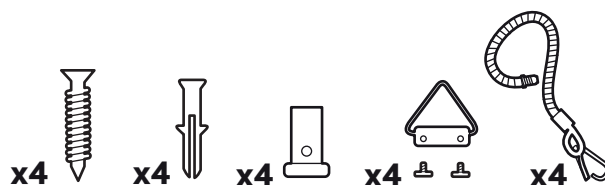

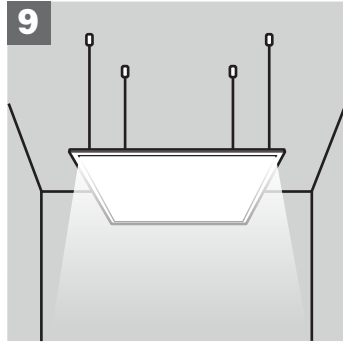
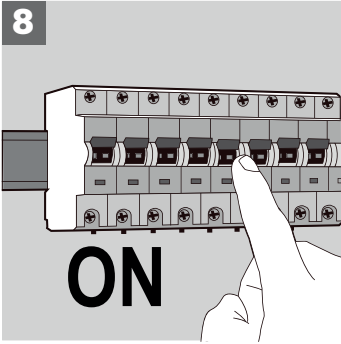
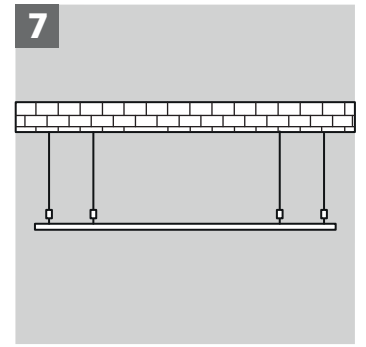
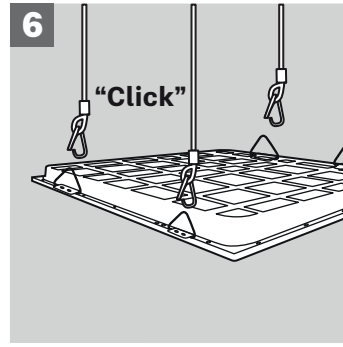
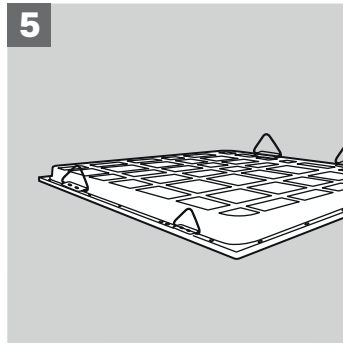
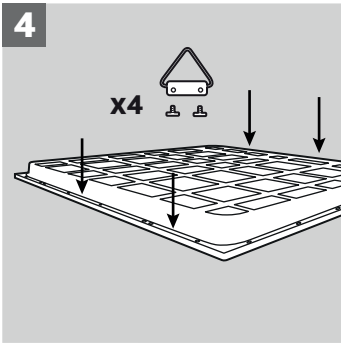

NUNCA COLOQUE EQUIPAMENTOS ELÉTRICOS E/OU ELETRÔNICOS NO LIXO DOMÉSTICO!

Segundo a diretiva europeia 2012/19/CE relativa aos resíduos de equipamentos elétricos e/ou eletrónicos e a respetiva transposição para o direito interno, os equipamentos usados têm de ser recolhidos separadamente e entregues nos locais de recolha previstos para o efeito.

Pode obter informações relativas à eliminação dos equipamentos usados através dos responsáveis legais pela reciclagem no seu município.

**NO DESECHE NUNCA LOS APARATOS ELÉCTRICOS Y/O ELECTRÓNICOS EN LA BASURA DOMÉSTICA.**

Según la norma europea 2012/19/CE al respecto de los residuos de herramientas eléctricas y electrónicas y su transposición para el derecho interno, estas herramientas tienen de ser recogidas separadamente y entregadas en los locales de recogida previsto al efecto.

Puede obtener información acerca de la eliminación de la máquina utilizada a través de los responsables legales del reciclaje en su municipio.

**NEVER DISPOSE OF ELECTRICAL AND/OR ELECTRONIC EQUIPMENT IN THE HOUSEHOLD WASTE!**

According to the European Directive 2012/19/EC on electrical and electronic equipment waste and its transposition into national law, power tools must be collected separately and delivered to the collection sites intended for this purpose. You can get information regarding the disposal of the power tool through the person in charge for recycling in your city.

**NE JETEZ JAMAIS LES ÉQUIPEMENTS ÉLECTRIQUES ET/OU ÉLECTRONIQUES AVEC LES ORDURES MÉNAGÈRES!**

D'après la directive européenne 2012/19/CE concernant les déchets d'équipements électriques et électroniques et à sa transposition en droit national, les outils électriques usagés doivent être collectés séparément et remis aux points de collecte prévus à cet effet. Vous pouvez obtenir des informations sur l'élimination de la visseuse à choc sans fil utilisé auprès des responsables du service environnement de votre commune.

**WERFEN SIE ELEKTRO- UND/ODER ELEKTRONIKGERÄTE NIEMALS IM HAUSMÜLL WEG!**

Gemäß der europäischen Richtlinie 2012/19/EG über Abfälle von Elektro- und Elektronikgeräten und deren Umsetzung in nationales Recht müssen gebrauchte Geräte separat gesammelt und an den dafür vorgesehenen Sammelstellen abgegeben werden. Weitere Informationen zur Entsorgung von Altgeräten erhalten Sie bei den zuständigen Stellen für Recycling in Ihrer Gemeinde.

**CERTIFICADO DE GARANTIA**

A garantia deste produto está de acordo com a lei em vigor a partir da data de compra. Deverá, pois, guardar a prova de compra durante esse período de tempo. A garantia engloba qualquer defeito de fabrico, de material ou de funcionamento, assim como os sobressalentes e trabalhos necessários para a sua recuperação.

Excluem-se da garantia a má utilização do produto, eventuais reparações efetuadas por pessoas não autorizadas (fora da assistência da marca ASLO), assim como qualquer estrago causado pela utilização da mesma.

CERTIFICADO DE GARANTIA

La garantía de este producto está en conformidad con la ley vigente a partir de la fecha de compra. Por lo tanto, debe guardar el comprobante de compra durante ese período de tiempo. La garantía cubre cualquier defecto de fabricación, material o funcionamiento, así como los repuestos y el trabajo necesario para su reparación.

Si excluyen de la garantía el malo uso del producto, eventual reparaciones efectuadas por personas no autorizadas (fuera de la asistencia de la marca ASLO), así como cualquier daño causado por el uso.

WARRANTY TERMS

The warranty for this product is in accordance with the law in force from the date of purchase. You should, therefore, keep your proof of purchase during this period. The warranty covers any manufacturing defect in material or operation, as well as parts and work needed for their repairing.

Excluded from the warranty are the misuse of the product, any repairs carried out by unauthorized individuals (outside the service center of the brand ASLO) as well as any damage caused by its use.

CERTIFICAT DE GARANTIE

La garantie de ce produit est conforme à la loi en vigueur à partir de la date d'achat. Vous devrez, pourtant, garder la preuve d'achat pendant cette période. La garantie englobe n'importe quel défaut de fabrication, du matériel ou de fonctionnement, ainsi que les pièces de rechange et les travaux nécessaires à sa récupération.

Sont exclues de la garantie la mauvaise utilisation du produit, les éventuelles réparations réalisées par des personnes non autorisées (en dehors de l'assistance de la marque ASLO), ainsi que n'importe quel dommage causé par l'utilisation de l'appareil.

GARANTIEZERTIFIKAT

Die Garantie für dieses Produkt richtet sich nach den geltenden gesetzlichen Bestimmungen ab dem Kaufdatum. Bewahren Sie daher unbedingt den Kaufbeleg für die Dauer des Garantiezeitraums auf.

Die Garantie umfasst alle Herstellungsfehler, Materialmängel sowie Funktionsstörungen, einschließlich der notwendigen Ersatzteile und Reparaturen zur Behebung der Mängel. Von der Garantie ausgenommen sind Schäden, die durch unsachgemäße Nutzung des Produkts, Reparaturen durch nicht autorisierte Personen (außerhalb des ASLO-Service) oder durch unsachgemäße Handhabung entstehen.

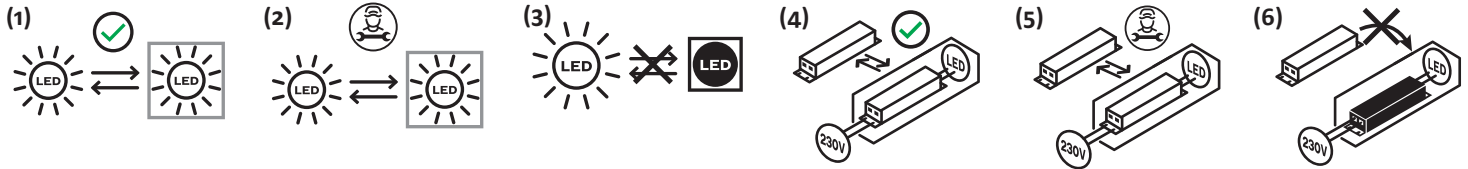

Este produto contém uma fonte de luz com classe de eficiência energética.

Substituibilidade: A (1) fonte de luz ou a (4) unidade de controlo podem ser substituídas pelo utilizador final sem causar danos permanentes à lâmpada. a (2) fonte de luz ou a (5) unidade de controlo podem ser substituídas por um electricista qualificado sem causar danos permanentes à lâmpada. A (3) fonte de luz ou a (6) unidade de controlo não podem ser substituídas, a lâmpada deve ser substituída.

Este producto contiene una fuente de luz de la clase de eficiencia energética.

Intercambiabilidad: La fuente de luz (1) o la unidad de alimentación (4) es sustituible por el usuario final sin que ello provoque daños permanentes en la luminaria. La fuente de luz (2) o la unidad de alimentación (5) es sustituible por parte de un electricista cualificado sin ello provoque daños permanentes en la luminaria. La fuente de luz (3) o la unidad de alimentación (6) no es sustituible; es necesario reemplazar la luminaria.

This product contains a light source with energy efficiency class.

Replaceability: (1) Light source or (4) operating device can be replaced by end users without permanent damage to the luminaire. (2) Light source or (5) operating device can be replaced by a qualified electrician without permanently damaging the luminaire. (3) Light source or (6) operating device is not replaceable, the luminaire must be replaced.

Ce produit comprend une ampoule de la classe d'efficacité énergétique.

Interchangeabilité: (1) L'ampoule ou (4) le contrôleur peut être remplacé par l'utilisateur final sans risque de dégradation du luminaire. (2) L'ampoule ou (5) le contrôleur peut être remplacé par un électricien professionnel sans risque de dégradation du luminaire. (3) L'ampoule ou (6) le contrôleur n'est pas remplaçable. Le luminaire doit être changé.

Dieses Produkt enthält eine Lichtquelle der Energieeffizienzklasse.

Austauschbarkeit: (1) Die Lichtquelle oder (4) die Steuereinheit können vom Endverbraucher selbst ausgetauscht werden, ohne dass die Lampe dauerhaft beschädigt wird. (2) Die Lichtquelle oder (5) die Steuereinheit können von einem qualifizierten Elektriker ersetzt werden, ohne dass die Lampe dabei dauerhaft beschädigt wird. (3) Die Lichtquelle oder (6) die Steuereinheit können nicht ausgetauscht werden, in diesem Fall muss die gesamte Lampe ersetzt werden.

DECLARAÇÃO UE DE CONFORMIDADE

CENTRAL LOBÃO S.A.

RUA DA GÂNDARA, 664

4520-606 S. JOÃO DE VER VFR

PT: Declara para os devidos efeitos que o artigo a seguir descrito:

ES: Declara para todos los efectos que el artículo siguiente:

EN: Declares for all due effects the product described bellow:

FR: Déclare que l'article décrit ci-dessous :

DE: Erklärt hiermit, dass das folgende Produkt:

PT: PAINEL LED 24W/40W UGR<19 3-CCT ES: PANEL LED 24W/40W UGR<19 3-CCT EN: LED PANEL LIGHT 24W/40W UGR<19 3-CCT FR: PANNEAU LED 24W/40W UGR<19 3-CCT DE: LED-PANEEL 24W/40W UGR<19 3-CCT	ASIGLA606040C3 ASIGLA306024C3 ASIGLA3012040C3
--	---

PT: Está de acordo com as seguintes normas ou documentos normativos (1) e conforme as diretivas (2):

ES: Cumple las siguientes normas o documentos normativos (1) y según las determinaciones de las directivas (2):

EN: Complies with the following standards or normative documents (1) and as defined by (2):

FR: Est conforme aux normes ou documents normatifs (1) suivants et selon les dispositions des directives (2) :

DE: Den folgenden Normen oder normativen Dokumenten (1) entspricht, in Übereinstimmung mit den Richtlinien (2):

(1) "EN IEC 55015:2019+A11, EN 61547:2023, EN IEC 61000-3-2:2019+A1, EN 61000-3-3:2013+A1+A2, EN IEC 60598-1:2021+A11, EN 60598-2-2:2012, IEC 62321-1:2013, IEC 62321-2:2021, IEC 62321-3-1:2013, IEC 62321-3-2:2013, IEC62321-4:2013+A1:2017, IEC 62321-5:2013, IEC 62321-6:2015, IEC 62321-7-1:2015, IEC 62321-7-2:2017, IEC 62321-8:2017"

(2) "2014/30/EU, 2014/35/EU, 2011/65/EU & (EU) 2015/863"

S. João de Ver, 31/03/2025

Processo técnico compilado por; Proceso técnico compilado por; Technical file compiled by;
Dossier technique compilé par; Technische Dokumentation erstellt von: Hugo Santos

Central Lobão S.A.
O Técnico Responsável
Hugo Santos



MADE IN P.R.C.

Aslo

BRIGHTER LIFE

aslo.pt

CENTRAL LOBÃO SA.
RUA DA GÂNDARA, 664
4520-606 S. J. VER
STA. M. FEIRA- PT



Raccolta differenziata



Points de collecte sur www.quefairedeusedechets.fr
Privilégiez la réparation ou le don de votre appareil !